

NU2111A I²C Controlled Single Cell High Efficiency 7-A Switched Cap Fast Charger

1 Feature

- 98.2% Efficient at Switched Cap Mode, 99.1% Efficient at Bypass Mode
- Switched Cap Architecture Optimized for 50% Duty Cycle.
 - Input Voltage is 2x Battery Voltage (3.0 V to 5.5 V)
 - Output Current is 2x of Input Current (Up to 3.5 A)
- Support Forward 2:1 and 1:1 Charge mode
- Support Reverse 1:2 and 1:1 Discharge mode
- Main Integrated Programmable Protection Features for Safe Operation
 - Input Over-Voltage Protection (BUS_OVP)
 - Input Over-Current Protection (BUS_OCP)
 - Input Under-Current Protection (BUS_UCP)
 - VDROPOver-Voltage Protection (DROP_OVP)
 - Battery Over-Voltage Protection (BAT_OVP)
 - Output Over-Voltage Protection (VOUT_OVP)
 - Voltage Tracking Protection (PMID2VOUT)
 - IBAT Over-Current Protection (BAT_OCP)
 - Thermal Shutdown Protection (TSD)
 - Battery or Connector Temperature Monitoring (NTC_FLT)
- Programmable Settings for System Optimization
 - IBUS, VBAT and IBAT Regulation Integrated
 - STAT, FLAG, and MASK Options for Interrupts
 - Selectable Switching Frequency from 300kHz to 1MHz with 100kHz Step
- Integrated 15-Bit Analog-to-Digital Converter (ADC)
 - ±1% BUS Voltage
 - ±4% BUS Current at 2.5A (0°C to 85°C)
 - ±1% VOUT Voltage
 - ±0.25% BAT Voltage with Differential Sensing
 - ±3% BAT Current at 6 A with External RSENSE =2mΩ (0°C to 85°C)
 - ±3°C Die Temperature (0°C to 85°C)

2 Applications

- Smart Phone
- Tablet PC
- Wearable

3 Descriptions

The NU2111A is a highly efficient, 7-A battery charging/discharging solution, employing switched cap and compatible bypass architectures. The switched cap architecture and integrated FETs are optimized for a 50% duty cycle, halving the cable current compared to the current delivered to the battery. This effectively minimizes losses over the charging cable and limits temperature rise in the application. Additionally, the dual-phase structure reduces both input capacitance requirements and output voltage ripple, enhancing overall performance.

Device Information

PART NUMBER	PACKAGE	BODY SIZE (mm)
NU2111A	WLCSP (36)	2.72×2.72

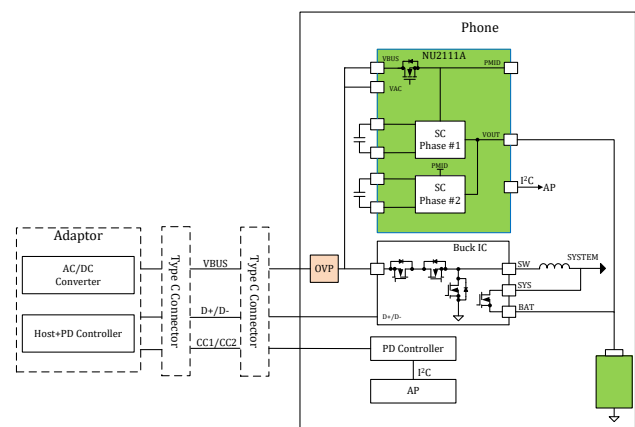

Figure 1. Simplified Application Diagram

This document contains confidential and proprietary information of NuVolta. Any information in this document is prohibited from being used, reproduced or disseminated to any third party in any form and/or through any means without the prior written consent of NuVolta. **ALL RIGHTS RESERVED.**