

# NU2105 I<sup>2</sup>C Controlled Single Cell High Efficiency 8-A Switched Cap Fast Charger

## 1 Feature

- 97.5% Efficient at 2:1 charge mode, 99.2% Efficient at 1:1 charge mode
- Switched Cap Architecture Optimized for 50% Duty Cycle.
  - Input Voltage is 2x Battery Voltage (3.5 V to 4.65v)
  - Output Current is 2x of Input Current (Up to 4.5 A)
  - Reduces Power Loss Across the Cable
- Support charge pump 2:1 and 1:1 charge mode
- Integrated Programmable Protection Features for Safe Operation
  - Input Over-Voltage Protection (BUS\_OVP)
  - Input Over-Current Protection (BUS\_OCP) with Adjustable Alarm
  - Input Over-Voltage with External OVP FET (VAC\_OVP up to 17V)
  - Battery Over-Voltage Protection (BAT\_OVP) with Adjustable Alarm
  - Output Over-Voltage (VOUT\_OVP)
  - IBAT Over-Current Protection (BAT\_OCP) with Adjustable Alarm
  - Battery Temperature Monitoring
  - Connector Temperature Monitoring
- Programmable Settings for System Optimization
  - Optional VBATERG and IBATERG Regulation for System Load and Wall Adapter Transients
  - STAT, FLAG, and MASK options for Interrupts
  - ADC Readings and Configuration
- Integrated 12-Bit Effective Analog-to-Digital Converter (ADC)
  - ±1% BUS Voltage
  - ±1% VOUT Voltage
  - ±0.5% BAT voltage with Differential Sensing
  - +2%/-4% BAT Current at 6 A with External 2m Ω of R<sub>SENSE</sub>

- +1%/-1.5% BAT and BUS Temperature
- ±5°C Die Temperature

## 2 Applications

- Smart Phone
- Tablet PC

## 3 Descriptions

The NU2105 is a 97.5% efficient, 8-A battery charging solution using a switched cap architecture. This architecture and the integrated FETs are optimized to enable a 50% duty cycle, allowing the cable current to be half the current delivered to the battery, reducing the losses over the charging cable as well as limiting the temperature rise in the application.

### Device Information

PART NUMBER	PACKAGE	BODY SIZE (NOM)
NU2105	WLCSP (56)	2.80mm×3.20mm

### Simplified Application

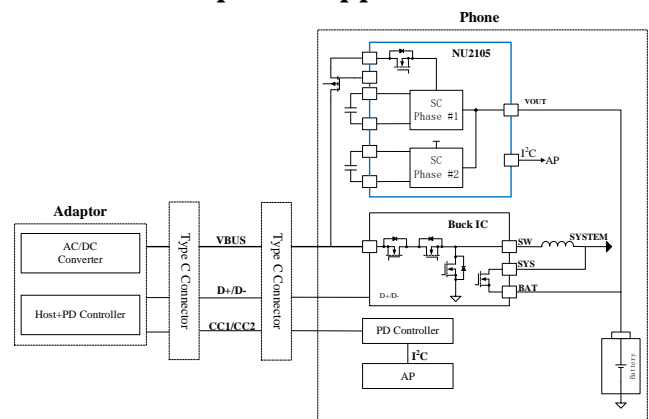

This document contains confidential and proprietary information of NuVolta. Any information in this document is prohibited from being used, reproduced or disseminated to any third party in any form and/or through any means without the prior written consent of NuVolta. **ALL RIGHTS RESERVED.**