

NU1030x 13.2V/12V High Efficiency Full-Bridge Power Stage Wireless Power Transmitter

1 Feature

- PVIN Input Voltage Range: 3.0V to 13.2V(NU10300)
- PVIN Input Voltage Range: 3.0V to 12V(NU10301)
- Integrated High-Efficiency Full- Bridge FETs and FET Driver Optimized for Low EMI
- High-Accuracy Input Current Measurement for FOD and In-Band Communication
- Integrated 2 channels Demodulation
- Robust UVLO / OVP / OCP and Thermal shut down Protection
- Ultra-Low quiescent current in Shut-down mode: <math><10\mu\text{A}</math>
- 3mmx3mm QFN Package

2 Applications

- Wireless Power Transmitter Compliant with WPC V2.0 Extended Power Profile (EPP), Max 15W(NU10300)/10W(NU10301) wireless transfer power
- Wireless Power Transmitter for Consumer, Industrial, Automotive Aftermarket, and Medical Applications

3 Descriptions

NU1030x is a high integrated efficiency power transmitter power stage, it integrates a full-bridge power stage designed for a wide frequency range (up to 2.0MHz), high accuracy current sense. Full-Bridge with adaptive deadtime control makes strong robust and high efficiency. Slew rate control optimizes the low -EMI design. VDD supply is able to output 4.8V by LDO to drive the external MCU. The

proprietary current-measurement circuit provides an accurate current signal to MCU used for the FOD (Foreign Object Detection) power measurement without extra sense resistor. It also includes protection functions such as input under-voltage lockout, over-voltage protection, over current protection, and thermal shutdown. These provisions further enhance the reliability of the total system solution.

The demodulation function is enhanced with two parallel channels output.

The device is housed in a thermally enhanced 3mmx3mm QFN package.

Device Information

PART NUMBER	PACKAGE	BODY SIZE (NOM)
NU10300	QFN20	3mmx3mm
NU10301	QFN24	3mmx3mm

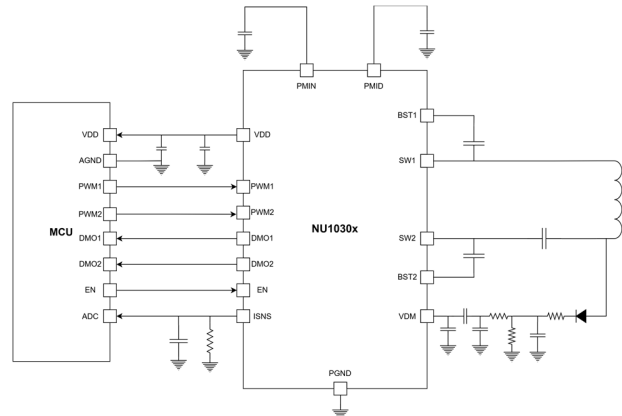

Figure 1. Simplified Application Diagram