

NU2112A I²C Controlled Single Cell High Efficiency 8-A Switched Cap Fast Charger

1 Feature

- 98.3% Efficient at Switched Cap Mode, 99.1% Efficient at Bypass Mode
- Switched Cap Architecture Optimized for 50% Duty Cycle.
 - Input Voltage is 2x Battery Voltage (3.0 V to 5.5 V)
 - Output Current is 2x of Input Current (Up to 4.0 A)
- Support Forward 2:1 and 1:1 Charge mode
- Support Reverse 1:2 and 1:1 Discharge mode
- BC1.2, VOOC and UFCS protocol Integrated via D+/D-
- Main Integrated Programmable Protection Features for Safe Operation
 - Input Over-Voltage with External OVP FET
 - Input Over-Voltage Protection (BUS_OVP)
 - Input Over-Current Protection (BUS_OCP)
 - Input Under-Current Protection (BUS_UCP)
 - VDROPOver-Voltage Protection (DROP_OVP)
 - Battery Over-Voltage Protection (BAT_OVP)
 - Output Over-Voltage Protection (VOUT_OVP)
 - Voltage Tracking Protection (PMID2VOUT)
 - IBAT Over-Current Protection (BAT_OCP)
 - Thermal Shutdown Protection (TSD)
- Programmable Settings for System Optimization
 - IBUSREG, VBATERG and IBATERG Regulation integrated.
 - STAT, FLAG, and MASK options for Interrupts
- Integrated 15-Bit Analog-to-Digital Converter (ADC)
 - ±1% BUS Voltage
 - ±4% BUS current at 2.5A (0°C to 85°C)
 - ±1% VOUT Voltage
 - 0~10mV BAT voltage at 4.4V with Differential Sensing
 - ±2.5% BAT Current at 6 A with External R_{SENSE} = 2mΩ (0°C to 85°C)

- ±3°C Die Temperature (0°C to 85°C)

2 Applications

- Smart Phone
- Tablet PC
- Wearable

3 Descriptions

NU2112A is a 98.3% efficient, 8-A battery charging/discharging solution with switched cap and compatible bypass architectures. The switched cap architecture and the integrated FETs are optimized to enable a 50% duty cycle, allowing the cable current to be half the current delivered to the battery, reducing the losses over the charging cable as well as limiting the temperature rise in the application. The dual-phase structure reduces the input cap requirements as well as reducing the output voltage ripple.

NU2112A will integrate BC1.2, VOOC and UFCS protocols.

Device Information

PART NUMBER	PACKAGE	BODY SIZE (mm)
NU2112A	WLCSP (36)	2.72x2.72

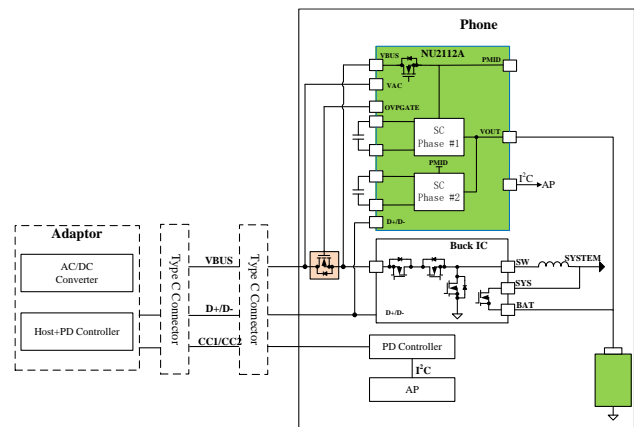

Figure 1. Simplified Application Diagram

This document contains confidential and proprietary information of NuVolta. Any information in this document is prohibited from being used, reproduced or disseminated to any third party in any form and/or through any means without the prior written consent of NuVolta. **ALL RIGHTS RESERVED.**