

Low Cost, None-firmware, High Integration Wireless Power Receiver

1 Feature

- Ultra-simple circuit structure with total only 12pcs components
- Low Cost and very simple application without extra firmware
- I²C programmability
- Integrated Low-Dropout LDO to Provide Regulated Output Programmable V_{out} from 3.5V to 9V with 39mV step
- Or Output V_{out} real-time tracking external Battery Voltage to optimize the efficiency
- Programmable and Configurable FOD gain and offset by I²C or Resistors
- Integrated high-efficiency synchronous rectifier without bootstrap capacitors
- Robust OVP, OCP, SCP and OTP Protection
- 10 Bits ADC for Battery voltage, Output current and temperature measurement
- INT Output for external interrupt
- Small Size with 16-QFN 3.0mm x 3.0mm, 0.5mm pitch

2 Applications

- WPC 5W BPP Compliant Receiver with Maximum 5W Received Power
- Wireless Power Receiver for TWS, Electric Toothbrush, Electric Shaver, E-Cigarette and others Consumer Equipment

3 Descriptions

NU1680 is a highly integrated wireless power receiver, which requires less quantity of surrounding components compared with NU1610. It gives the benefit of the very low.

total system cost and less PCB area for wireless power receiver solution. Also, since requires no firmware to program, it will much simplify the design effort and consolidate the solution more easily and quickly. It integrates a synchronous rectifier without bootstrap capacitors designed

for a high efficiency purpose and low cost. The regulator can provide a wide range regulated voltage from 3.5V to 9V compliable with different applications. Furthermore, it can regulate the output voltage tracking the battery voltage to further lower down the charging system power loss.

NU1680 can conduct communication with a transmitter system through ASK. The communication is compliant with WPC V1.2.4. FOD parameters can be configured by I²C interface or external resistors to pass the FOD test.

NU1680 also support to be connected to a main AP, communicated by I²C interface. It provides external interrupt, ADC value of battery voltage and output current etc.

NU1680 also includes standard protection functions such as overcurrent protection, short-circuit protection, overvoltage protection and thermal shutdown. These provisions further enhance the reliability of the system solution.

The device is housed in a compact 3.0mm×3.0mm QFN package.

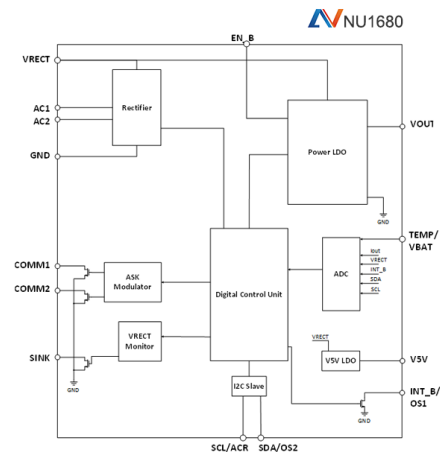

This document contains confidential and proprietary information of NuVolta. Any information in this document is prohibited from being used, reproduced or disseminated to any third party in any form and/or through any means without the prior written consent of NuVolta. **ALL RIGHTS RESERVED.**