

# High Efficiency, High Integration Wireless Power Transmitter Controller

## 1 Features

- Wide Input Voltage: 4.5V to 30V
- Integrated Boost/Buck Controller, output voltage range is 5V to 45V with 25mV step
- Integrated 3 pair Half-Bridge Drivers with controllable dead-time and slew rate
- Integrated 5V, 3.3V and 1.8V LDO
- High-Accuracy Current Measurement for FOD and In-Band Communication
- Integrated high precision Q Factor and LC resonant Frequency Measurement
- Integrated Low-Error-Rate Digital Demodulation
- Robust OVP, UVP, OCP, OJP (Juggle Protection) and TSD Protection
- I<sup>2</sup>C Master/Slave and UART Interfaces
- 13 channel, 14bit ADC
- Integrated 91.996MHz, 32Bit/64K MTP/4K SRAM MCU Core
- Integrated QC/PD3.0(PPS) protocol function
- Ultra-Low quiescent current in SLEEP mode: <20uA
- 6 mm × 6 mm QFN48 Package

## 2 Applications

- Wireless Power Transmitter Compliant with WPC V1.3 Extended Power Profile (EPP) 15W
- Wireless Power Transmitter for Consumer, Industrial, Automotive Aftermarket, and Medical Applications

## 3 Descriptions

NU1718 is a highly integrated wireless power transmitter controller. It integrates a buck/boost controller designed for power-stage input voltage regulation, 4 pair Half-Bridge drivers, a 32bit MCU core and a fast charge block of QC/PD protocol.

NU1718 integrates all critical functions of power system, such as low-EMI FET drivers, bootstrap circuit, 5V/3.3V/1.8V LDO power supply, high-accuracy current measurement. The proprietary current-measurement circuit provides the accurate current reading used for the FOD (Foreign Object Detection) power measurement, in-band communication, Q factor detection, and ASK demodulation. It also includes protection functions such as input under-voltage lockout, over-voltage protection, over current protection, innovative unique Juggle Protection circuit, and thermal shutdown. These provisions further enhance the reliability of the total system solution.

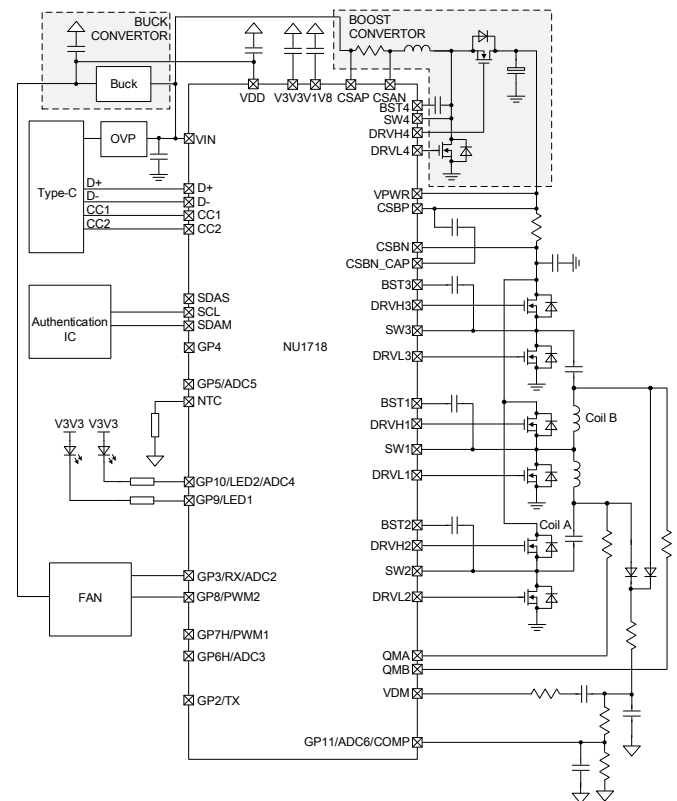

**Simplified Application Diagram**

This document contains confidential and proprietary information of NuVolta. Any information in this document is prohibited from being used, reproduced or disseminated to any third party in any form and/or through any means without the prior written consent of NuVolta. **ALL RIGHTS RESERVED.**